

Dual Display Digital Pressure Sensor

DP-100 SERIES

- FIBER SENSORS
- LASER SENSORS
- PHOTOELECTRIC SENSORS
- MICRO PHOTOELECTRIC SENSORS
- AREA SENSORS
- SAFETY COMPONENTS
- PRESSURE SENSORS**
- INDUCTIVE PROXIMITY SENSORS
- PARTICULAR USE SENSORS
- SENSOR OPTIONS
- WIRE-SAVING SYSTEMS
- MEASUREMENT SENSORS
- STATIC CONTROL DEVICES
- LASER MARKERS

Related Information	General terms and conditionsP.1	Sensor selection guideP.11~ / P.593~
	Glossary of terms / General precautionsP.1000~ / P.1004	Korea's S-mark P.1034~

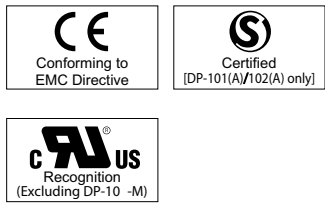

Dual 3-color display makes operation easier!

The dual display means that the "current value" and the "threshold value", it makes direct setting of threshold value

Equipped with a 30 mm 1.181 in square compact-sized dual display. Because the current value and the threshold value can be checked at the same time, the threshold value can be set and checked smoothly without having to switch screen modes. ON / OFF operations are still carried out while the threshold values are being set, so setting to the same sensitivity as dial control-type sensors is possible. And naturally a key lock function is also equipped.

Selection Guide
Digital Display
DP-100
DP4
DP-M
Head-separated
DP5 / DPH
Other Products

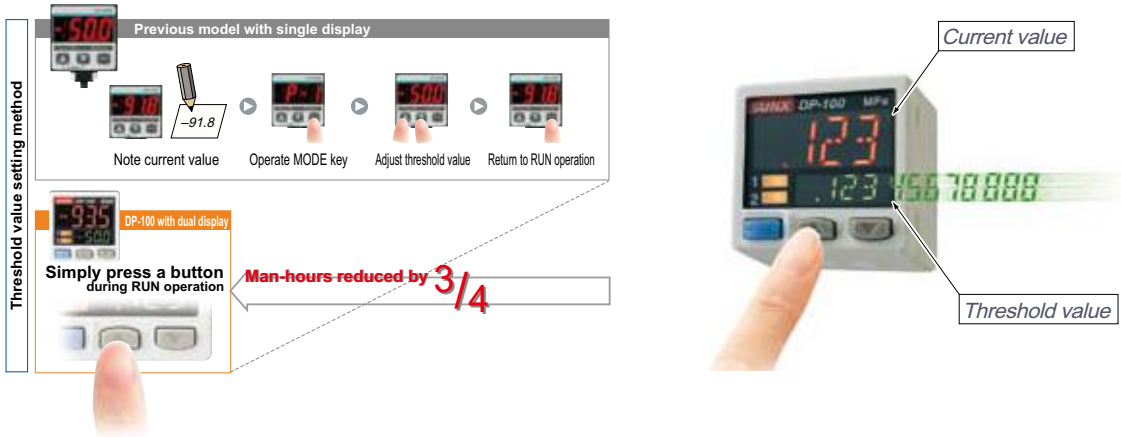

3-color display (Red, Green, Orange)

The main display changes color in line with changes in the status of output ON / OFF operation, and it also changes color while setting is in progress. The sensor status can therefore be understood easily, and operating errors can be reduced.

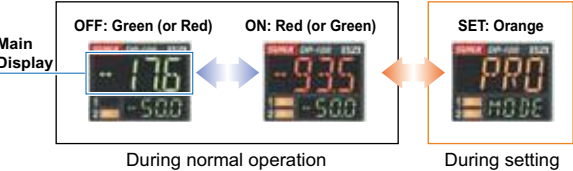

Readable digital display

12 segments are used and an alphanumeric display has been adopted. This improves visual checking of letters and numbers.



APPLICATIONS

Confirming suction of electronic component

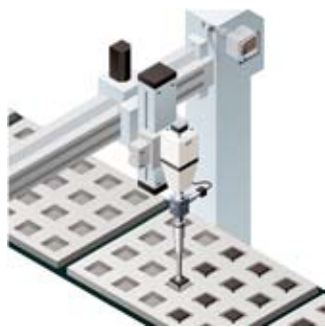

Confirming reference pressure



Air-leak test for PET bottles



BASIC PERFORMANCE

All models in the line-up are compound pressure types

No sensor settings are required to switch between positive pressure and negative pressure, so that the number of registered part numbers can be decreased.

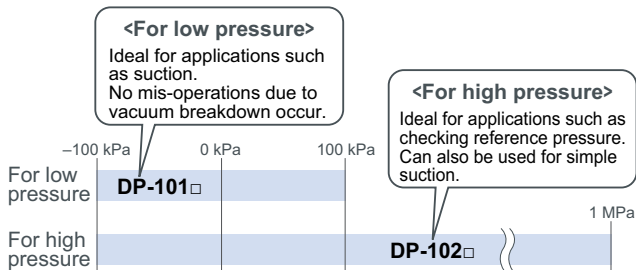

Realizes high performance **Low pressure type**

The low pressure type displays measurements in 0.1 kPa at a resolution of 1/2,000 and has a response time of 2.5 ms (variable up to 5,000 ms), ±0.5 % F.S. temperature characteristics and ±0.1 % F.S. repeatability, giving it high performance.

- Resolution: 1/2,000
- Response time: 2.5 ms
- Temperature characteristics: ±0.5 % F.S.
- Repeatability: ±0.1 % F.S.



Displays measurements in 0.1 kPa

FUNCTIONS

Copy function reduces man-hours and human error

Sensors can be connected to a master sensor one by one, and a copy of the setting details for the master sensor can be transmitted as data to the other sensors. If making the same settings for multiple sensors, this prevents setting errors from occurring with the other sensors and also reduces the number of changes required to instruction manuals when equipment designs are changed.

Copying via wiring

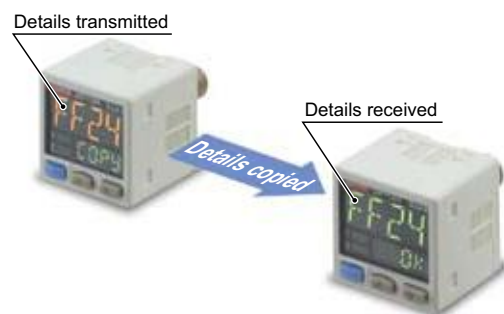
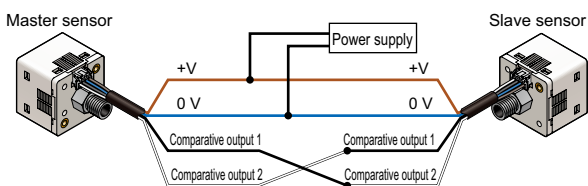

The sensor's setting operation mode has a 3-level configuration to suit the frequency of use

The setting levels are clearly separated into "RUN mode" for operation settings that are carried out daily, "MENU SETTING mode" for basic settings, and "PRO mode" for special and detailed setting. These make setting operations easy to understand and easy to carry out.

Simple setting

RUN mode

MENU SETTING mode

Special and detailed setting

PRO mode

RUN mode

Settings such as threshold value adjustment and key lock operation can be carried out while the sensor is operating.

MENU SETTING mode

Basic settings such as output mode setting and NO / NC switching can be carried out.

PRO mode

High-level function settings such as hysteresis adjustment and the copy function can be carried out.

- FIBER SENSORS
- LASER SENSORS
- PHOTOELECTRIC SENSORS
- MICRO PHOTOELECTRIC SENSORS
- AREA SENSORS
- SAFETY COMPONENTS
- PRESSURE SENSORS**
- INDUCTIVE PROXIMITY SENSORS
- PARTICULAR USE SENSORS
- SENSOR OPTIONS
- WIRE-SAVING SYSTEMS
- MEASUREMENT SENSORS
- STATIC CONTROL DEVICES
- LASER MARKERS

- Selection Guide
- Digital Display
- DP-100**
- DP4**
- DP-M**
- Head-separated
- DP5 / DPH**
- Other Products

FIBER SENSORS
LASER SENSORS
PHOTOELECTRIC SENSORS
MICRO PHOTOELECTRIC SENSORS
AREA SENSORS
SAFETY COMPONENTS
PRESSURE SENSORS
INDUCTIVE PROXIMITY SENSORS
PARTICULAR USE SENSORS
SENSOR OPTIONS
WIRE-SAVING SYSTEMS
MEASUREMENT SENSORS
STATIC CONTROL DEVICES
LASER MARKERS
Selection Guide
Digital Display
DP-100
DP4
DP-M
Head-separated
DP5 / DPH
Other Products

FUNCTIONS

Equipped with independent dual output and three output modes

Standard type

Equipped with two independent comparative outputs, and separate sensing modes can be selected for each of them. Since there are two comparative outputs, one of the comparative outputs can... One of the comparative outputs can even be used for alarm output. In addition, if an output is not being used, it can be disabled.

Vacuum breakdown can also be checked during suction applications!

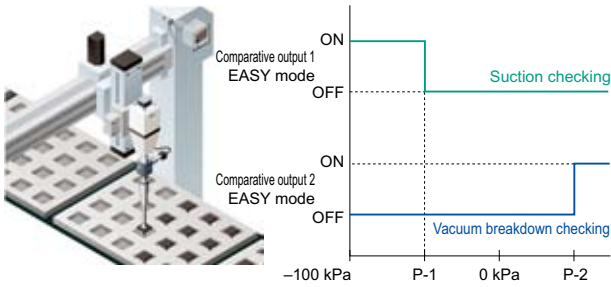

Reference pressure alarm output is possible during reference pressure checking!

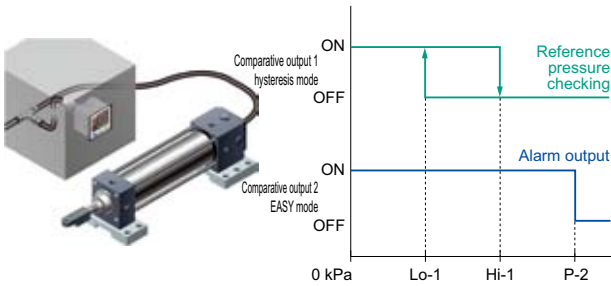

Equipped with auto-reference / remote zero-adjustment functions, more precise pressure management is possible with a minimum of effort

Multi-function type

If the reference pressure of the device changes, the auto-reference function partially shift the comparative output judgment level by the amount that the reference pressure shifts, and the remote zero-adjustment function can reset the display value to zero via external input. These functions are ideal for places where the reference pressure fluctuates wildly, or where fine settings are desired.

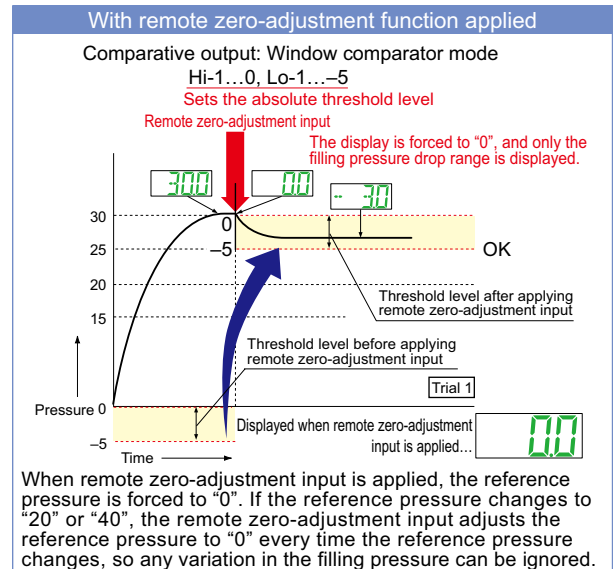
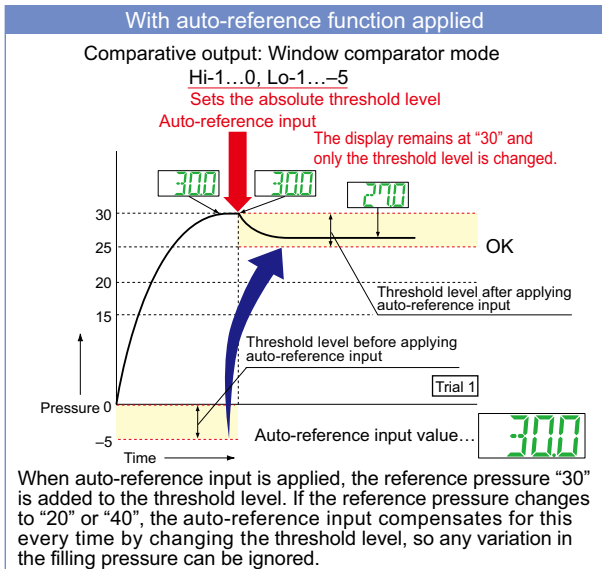

① EASY mode

This mode is used for comparative output ON / OFF control.

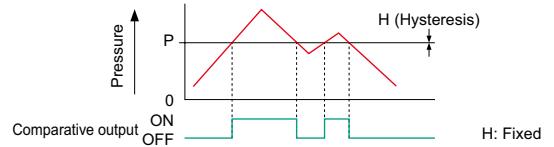

Notes: 1) Hysteresis can be fixed to one of eight different levels.
2) "P-1" appears in the sub display for comparative output 1, and "P-2" appears for comparative output 2.

② Hysteresis mode

This mode is used for setting comparative output hysteresis to the desired level and for carrying out ON / OFF control.

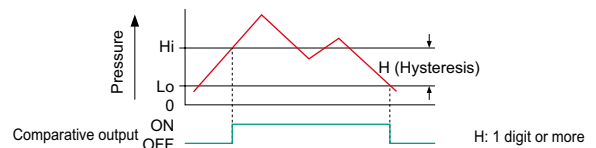

Note: "Hi-1" or "Lo-1" appears in the sub display for comparative output 1, and "Hi-2" or "Lo-2" appears for comparative output 2.

③ Window comparator mode

This mode is used for setting comparative output ON and OFF at pressures within the setting range.

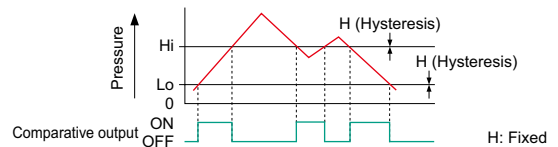

Notes: 1) Hysteresis can be fixed to one of eight different levels.
2) "Hi-1" or "Lo-1" appears in the sub display for comparative output 1, and "Hi-2" or "Lo-2" appears for comparative output 2.

FUNCTIONS

Sub display can be customized

The sub display can be set to indicate any other desired values or letters apart from the threshold value. This eliminates the need for tasks such as affixing a label to the device to indicate the normal pressure value.



Setting details can be understood at a glance

The DP-100 setting details appear in the digital display. Because the settings are in numeric form that can be easily understood, it is useful for times such as when receiving technical support by telephone.

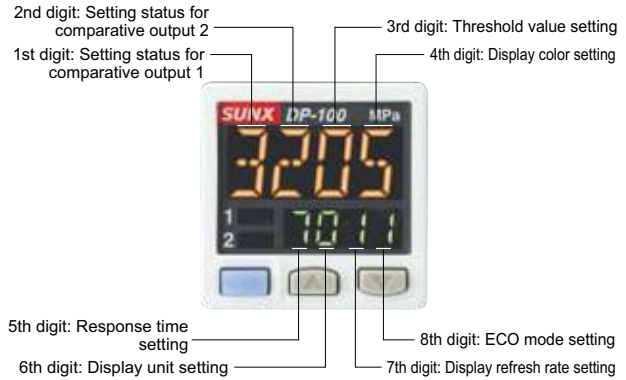

MOUNTING

Tight installation to panels is possible

An exclusive mounting bracket that is suitable for 1 to 6 mm 0.039 to 0.236 in panel thickness is available.

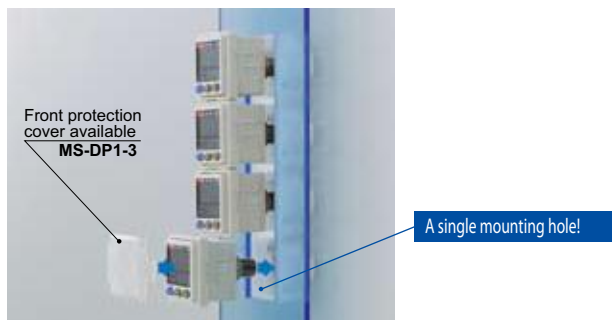

An exclusive mounting bracket (MS-DP1-1) that supports tight installation is available

Space savings can also be obtained if an L-shaped mounting bracket is used.

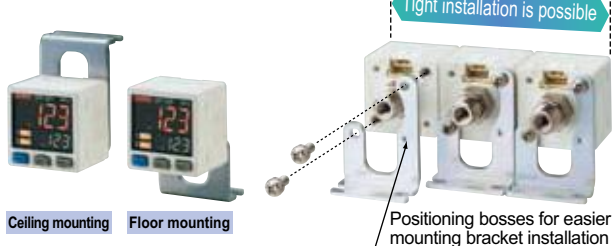

Cable can be connected with one-touch connection

The accessory connector attached cable (2 m 6.562 ft) can be connected easily with one-touch connection.



* Options: 1 m 3.281 ft / 3 m 9.843 ft / 5 m 16.404 ft types are also available. Please see P.600 for information about the recommended commercially available connectors.

NEW Short pressure port type is lightweight and takes up little space

DP-10 -M

Compact size with a depth of only 30 mm 1.181 in, so that it can easily fit into narrow spaces. Further, 10 g lighter than standard types. This reduces the loads on movable parts such as robot arms.

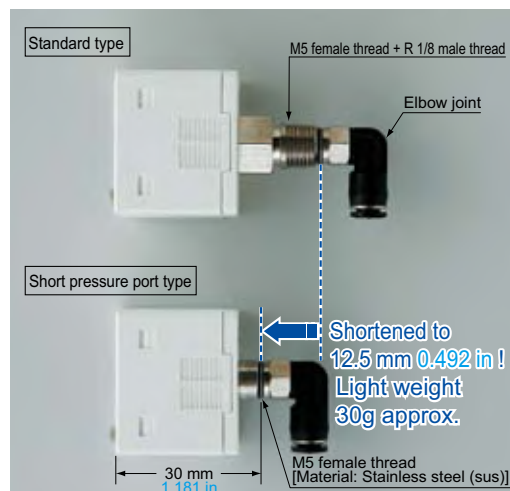
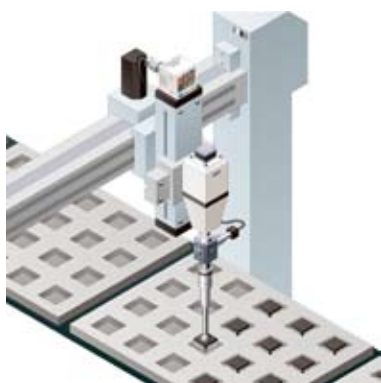

* The illustration shows connection using an elbow joint. The elbow joint is sold separately.

FIBER SENSORS

LASER SENSORS

PHOTOELECTRIC SENSORS

MICRO PHOTOELECTRIC SENSORS

AREA SENSORS

SAFETY COMPONENTS

PRESSURE SENSORS

INDUCTIVE PROXIMITY SENSORS

PARTICULAR USE SENSORS

SENSOR OPTIONS

WIRE-SAVING SYSTEMS

MEASUREMENT SENSORS

STATIC CONTROL DEVICES

LASER MARKERS

Selection Guide

Digital Display

DP-100

DP4

DP-M

Head-separated

DP5 / DPH

Other Products

MOUNTING

NEW M8 plug-in connector types are also available. (Only for Europe)

DP-11 -E-P-J



ORDER GUIDE

		Type	Appearance	Rated pressure range	Model No.	Pressure port	Comparative output	
Standard pressure port type	Asia	Standard	For low pressure	-100.0 to +100.0 kPa	DP-101	M5 female thread + R (PT) 1/8 male thread	NPN open-collector transistor	
			For high pressure	-0.100 to +1.000 MPa	DP-102			
		Multi-function	For low pressure	-100.0 to +100.0 kPa	DP-101A			
			For high pressure	-0.100 to +1.000 MPa	DP-102A			
	Europe	Standard	For low pressure	-100.0 to +100.0 kPa	DP-101-E-P	M5 female thread + G 1/8 male thread	PNP open-collector transistor	
			For high pressure	-0.100 to +1.000 MPa	DP-102-E-P			
			Multi-function	For low pressure	-100.0 to +100.0 kPa			DP-101A-E-P
				For high pressure	-0.100 to +1.000 MPa			DP-102A-E-P
		M8 plug-in connector type	Standard	For low pressure	-100.0 to +100.0 kPa	DP-111-E-P-J	M5 female thread + G 1/8 male thread	PNP open-collector transistor
				For high pressure	-0.100 to +1.000 MPa	DP-112-E-P-J		
			Multi-function	For low pressure	-100.0 to +100.0 kPa	DP-111A-E-P-J		
				For high pressure	-0.100 to +1.000 MPa	DP-112A-E-P-J		
North America	Standard	For low pressure	-100.0 to +100.0 kPa	DP-101-N	M5 female thread + NPT 1/8 male thread	NPN open-collector transistor		
		For high pressure	-0.100 to +1.000 MPa	DP-101-N-P				
		Multi-function	For low pressure	-100.0 to +100.0 kPa			DP-102-N	
			For high pressure	-0.100 to +1.000 MPa			DP-102-N-P	
	M8 plug-in connector type	Standard	For low pressure	-100.0 to +100.0 kPa		DP-101A-N	M5 female thread + NPT 1/8 male thread	NPN open-collector transistor
			For high pressure	-0.100 to +1.000 MPa		DP-101A-N-P		
		Multi-function	For low pressure	-100.0 to +100.0 kPa		DP-102A-N		
			For high pressure	-0.100 to +1.000 MPa		DP-102A-N-P		
Short pressure port type	Asia	Standard	For low pressure	-100.0 to +100.0 kPa	DP-101-M	M5 female thread	NPN open-collector transistor	
			For high pressure	-0.100 to +1.000 MPa	DP-102-M			
		Multi-function	For low pressure	-100.0 to +100.0 kPa	DP-101A-M			
			For high pressure	-0.100 to +1.000 MPa	DP-102A-M			



*CN-14A-C2 (Connector attached cable 2 m 6.562 ft) is attached. (Excluding M8 plug-in) connector type

Type without connector attached cable

Type without connector attached cable CN-14A-C2 is available. When ordering this type, suffix "-J" to the Model No. (e.g.) Type without connector attached cable of DP-101-N is "DP-101-N-J"

Accessory

- CN-14A-C2 (Connector attached cable 2 m 6.562 ft)



FIBER SENSORS
LASER SENSORS
PHOTO-ELECTRIC SENSORS
MICRO PHOTO-ELECTRIC SENSORS
AREA SENSORS
SAFETY COMPONENTS
PRESSURE SENSORS
INDUCTIVE PROXIMITY SENSORS
PARTICULAR USE SENSORS
SENSOR OPTIONS
WIRE-SAVING SYSTEMS
MEASUREMENT SENSORS
STATIC CONTROL DEVICES
LASER MARKERS
Selection Guide
Digital Display
DP-100
DP4
DP-M
Head-separated
DP5 / DPH
Other Products

OPTIONS

Designation	Model No.	Description		
Connector attached cable	CN-14A-C1	Length: 1 m 3.281 ft	0.2 mm ² 4-core cabtyre cable with connector on one end Cable outer diameter: $\phi 3.7$ mm $\phi 0.146$ in	
	CN-14A-C2(Note)	Length: 2 m 6.562 ft		
	CN-14A-C3	Length: 3 m 9.843 ft		
	CN-14A-C5	Length: 5 m 16.404 ft		
Connector attached cable (Flexible cable)	CN-14A-R-C1	Length: 1 m 3.281 ft		
	CN-14A-R-C2	Length: 2 m 6.562 ft		
	CN-14A-R-C3	Length: 3 m 9.843 ft		
	CN-14A-R-C5	Length: 5 m 16.404 ft		
M8 connector attached cable	CN-24A-C2	Length: 2 m 6.562 ft		For M8 plug-in connector type The connector on one end Cable outer diameter: $\phi 4$ mm $\phi 0.157$ in
	CN-24A-C5	Length: 5 m 16.404 ft		
Connector	CN-14A	Set of 10 housings and 40 contacts		
Sensor mounting bracket	MS-DP1-1	Allows sensors to be installed to face in the direction of the floor or ceiling. Multiple sensors can also be mounted closely.		
Panel mounting bracket	MS-DP1-2	Allows installation to panels with thickness of 1 to 6 mm 0.039 to 0.236 in.		
Front protection cover	MS-DP1-3	Protects the adjustment surfaces of sensors. (Can be attached when using the panel mounting bracket)		
Panel mounting bracket for DP2 / DP3 replacement	MS-DP1-4	The existing panel mounting holes can be used as they are to replace the existing model with the DP-100. This means that only DP-100 series parts are needed for replacement parts even when using previous models.		

Note: The connector attached cable CN-14A-C2 is supplied with the DP-100 series.
(Excluding M8 plug-in connector type).

Recommended connector.

Contact: SPHD-001T-P0.5, Housing: PAP-04V-S
(Manufactured by J.S.T. Mfg.Co., Ltd.)

Note: Contact the manufacturer for details of the recommended products.

Recommended crimping tool.

Model No.: YC-610R
(Manufactured by J.S.T. Mfg. Co., Ltd.)

Note: Contact the manufacturer for details of the recommended products.

Connector attached cable

- CN-14A-C
- CN-14A-R-C



M8 connector attached cable

- CN-24A-C

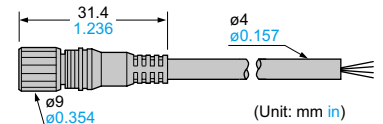

Sensor mounting bracket

- MS-DP1-1

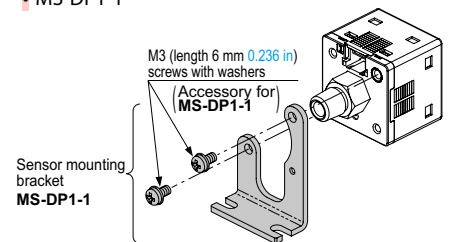

Panel mounting bracket

Front protection cover

- MS-DP1-2
- MS-DP1-3

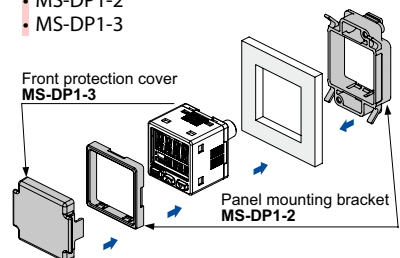

Panel mounting bracket for DP2 / DP3 replacement

- MS-DP1-4

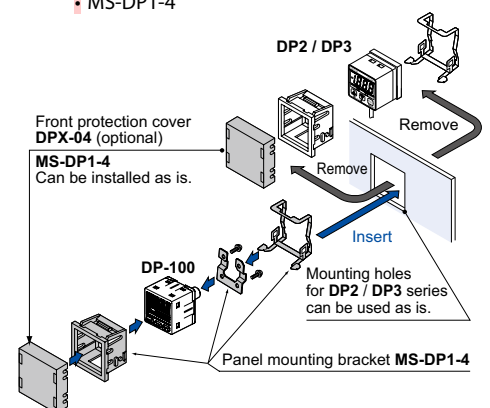

FIBER SENSORS

LASER SENSORS

PHOTO-ELECTRIC SENSORS

MICRO PHOTO-ELECTRIC SENSORS

AREA SENSORS

SAFETY COMPONENTS

PRESSURE SENSORS

INDUCTIVE PROXIMITY SENSORS

PARTICULAR USE SENSORS

SENSOR OPTIONS

WIRE-SAVING SYSTEMS

MEASUREMENT SENSORS

STATIC CONTROL DEVICES

LASER MARKERS

Selection Guide

Digital Display

DP-100

DP4

DP-M

Head-separated

DP5 / DPH

Other Products

SPECIFICATIONS

Item	Type	Standard		Multi-function	
		For low pressure		For high pressure	
		For low pressure	For high pressure	For low pressure	For high pressure
Model No.	Asia (Note 2)	DP-101(-M)	DP-102(-M)	DP-101A(-M)	DP-102A(-M)
	Europe	DP-101-E-P	DP-102-E-P	DP-101A-E-P	DP-102A-E-P
	M8 plug-in connector type	DP-111-E-P-J	DP-112-E-P-J	DP-111A-E-P-J	DP-112A-E-P-J
	North America (Note 2)	DP-101-N(-P)	DP-102-N(-P)	DP-101A-N(-P)	DP-102A-N(-P)
Type of pressure	Gauge pressure				
Rated pressure range	-100.0 to +100.0 kPa		-0.100 to +1.000 MPa		-100.0 to +100.0 kPa
Set pressure range	-100.0 to +100.0 kPa -1.020 to +1.020 kgf/cm ² -1.000 to +1.000 bar -14.50 to +14.50 psi -750 to +750 mmHg -29.5 to +29.5 inHg		-0.100 to +1.000 MPa -100 to +1,000 kPa -1.02 to +10.20 kgf/cm ² -1.00 to +10.00 bar -14.6 to +145.0 psi		-100.0 to +100.0 kPa -1.020 to +1.020 kgf/cm ² -1.000 to +1.000 bar -14.50 to +14.50 psi -750 to +750 mmHg -29.5 to +29.5 inHg
Pressure withstandability	500 kPa		1.5 MPa		500 kPa
Applicable fluid	Non-corrosive gas				
Selectable unit	For low pressure: kPa, kgf/cm ² , bar, psi, mmHg, inHg, For high pressure: MPa, kPa, kgf/cm ² , bar, psi				
Supply voltage	12 to 24 V DC ± 10 % Ripple P-P 10 % or less				
Power consumption	Normal operation: 840 mW or less (Current consumption 35 mA or less at 24 V supply voltage) ECO mode: 600 mW or less at STD (Current consumption 25 mA or less at 24 V supply voltage) 480 mW or less at FULL (Current consumption 20 mA or less at 24 V supply voltage)				
Comparative output	<Asia, North America (NPN output)> NPN open-collector transistor • Maximum sink current: 100 mA • Applied voltage: 30 V DC or less (between comparative output and 0 V) • Residual voltage: 2 V or less (at 100 mA sink current)		<Europe, North America (PNP output)> PNP open-collector transistor • Maximum source current: 100 mA • Applied voltage: 30 V DC or less (between comparative output and +V) • Residual voltage: 2 V or less (at 100 mA source current)		
Output operation / Output modes	NO / NC (selectable by key operation) / EASY mode / Hysteresis mode / Window comparator mode				
Hysteresis	Minimum 1 digit (variable) (however, 2 digits when using psi unit)				
Repeatability	±0.1 % F.S. (within ±2 digits)		±0.2 % F.S. (within ±2 digits)		±0.1 % F.S. (within ±2 digits)
Response time	2.5 ms, 5 ms, 10 ms, 25 ms, 50 ms, 100 ms, 250 ms, 500 ms, 1,000 ms, 5,000 ms, selectable by key operation				
Short-circuit protection	Incorporated				
External input (Auto-reference function / Remote zero-adjustment function)	—		<Asia, North America (NPN output)> ON voltage: 0.4 V DC or less OFF voltage: 5 to 30 V DC, or open Input impedance: 10 kΩ approx. Input time: 1 ms or more		<Europe, North America (PNP output)> ON voltage: 5 V to +VDC OFF voltage: 0.6 V DC or less, or open Input impedance: 10 kΩ approx. Input time: 1 ms or more
Analog voltage output	—		Output voltage: 1 to 5 V DC Zero point: within 3 V ± 5 % F.S. Span: within 4 V ± 5 % F.S. Linearity: within ±1 % F.S. Output impedance: 1 kΩ approx.		Output voltage: 0.6 to 5 V Zero point: within 1 V ± 5 % F.S. Span: within 4.4 V ± 5 % F.S. Linearity: within ±1 % F.S. Output impedance: 1 kΩ approx.
Display	4 digits + 4 digits 3-color LCD display (Display refresh rate: 250 ms, 500 ms, 1,000 ms, selectable by key operation)				
Displayable pressure range	-100.0 to +100.0 kPa -1.020 to +1.020 kgf/cm ² -1.000 to +1.000 bar -14.50 to +14.50 psi -750 to +750 mmHg -29.5 to +29.5 inHg		-0.100 to +1.000 MPa -100 to +1,000 kPa -1.02 to +10.20 kgf/cm ² -1.00 to +10.00 bar -14.6 to +145.0 psi		-100.0 to +100.0 kPa -1.020 to +1.020 kgf/cm ² -1.000 to +1.000 bar -14.50 to +14.50 psi -750 to +750 mmHg -29.5 to +29.5 inHg
Indicator	Orange LED (Comparative output 1 operation indicator, comparative output 2 operation indicator: Lights up when each comparative output is ON)		Orange LED (Comparative output 1 operation indicator: Lights up when comparative output is ON, Analog voltage output operation indicator: Lights up when setting)		
Protection	IP40 (IEC) (Refer to p.1001 for details of standards.)				
Ambient temperature	-10 to +50 °C +14 to +122 °F, Storage: -10 to +60 °C +14 to +140 °F (No dew condensation or icing allowed)				
Ambient humidity	35 to 85 % RH, Storage: 35 to 85 % RH				
Voltage withstandability	1,000 V AC for one min. between all supply terminals connected together and enclosure				
Insulation resistance	50 MΩ, or more, with 500 V DC megger between all supply terminals connected together and enclosure				
Vibration resistance	10 to 500 Hz frequency, 3 mm 0.118 in amplitude, in X, Y and Z directions for two hours each (when panel is mounted: 10 to 150 Hz frequency, 0.75 mm 0.030 in amplitude, in X, Y and Z directions for two hours each)				
Shock resistance	100 m/s ² acceleration (10 G approx.) in X, Y and Z directions for three times each				
Temperature characteristics	Within ±0.5 % F.S. (at +20 °C +68 °F)		Within ±1 % F.S. (at +20 °C +68 °F)		Within ±0.5 % F.S. (at +20 °C +68 °F)
Pressure port	Asia: M5 female thread + R (PT) 1/8 male thread (excluding DP-10 -M), Europe: M5 female thread + G 1/8 male thread, North America: M5 female thread + NPT 1/8 male thread				
Material	Enclosure: PBT (glass fiber reinforced), LCD display: Acrylic, Pressure port: Brass (nickel plated)[Asia, DP- J: Stainless steel (SUS)], Mounting threaded part: Brass (nickel plated), Switch part: Silicone rubber				
Connecting method / Cable length	Connector / Total length up to 100 m 328.084 ft (less than 10 m 32.808 ft when conforming to CE marking) is possible with 0.3 mm ² , or more, cable.				
Weight	Net weight: 40 g approx. (DP-10 -M: 30 g approx.), Gross weight: 135 g approx. (DP-10 -M: 125 g approx.)				
Accessories	CN-14A-C2 (Connector attached cable 2 m 6.562 ft): 1pc. (Excluding M8 plug-in connector type)				

Notes: 1) Where measurement conditions have not been specified precisely, the conditions used were an ambient temperature of +20 °C +68 °F.

2) Model Nos. of Asia type having the suffix "-M" are short pressure port type. Model Nos. of North America type having the suffix "-P" are PNP output type.

I/O CIRCUIT AND WIRING DIAGRAMS

DP-10

NPN output type

I/O circuit diagram

Standard type

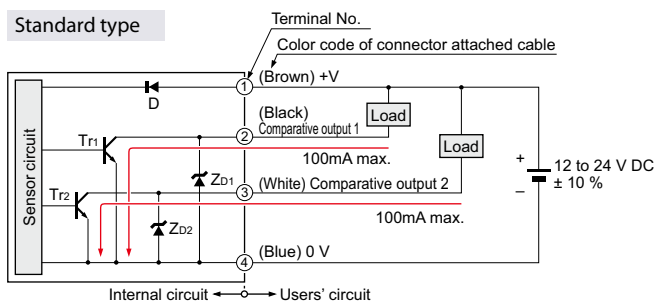

Symbols ... D: Reverse supply polarity protection diode
ZD1, ZD2: Surge absorption zener diode
Tr1, Tr2: NPN output transistor

Multi-function type

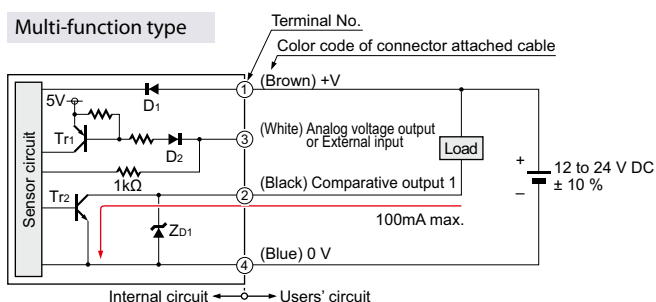

Symbols ... D1, D2: Reverse supply polarity protection diode
ZD1: Surge absorption zener diode
Tr1 : PNP input transistor
Tr2 : NPN output transistor

Terminal arrangement diagram

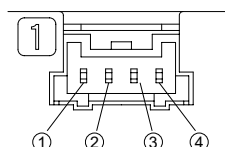

Terminal No.	Designation
①	+V
②	Comparative output 1
③	Standard type: Comparative output 2 Multi-function type: Analog voltage output or External input
④	0 V

DP-10 -P

PNP output type

I/O circuit diagram

Standard type

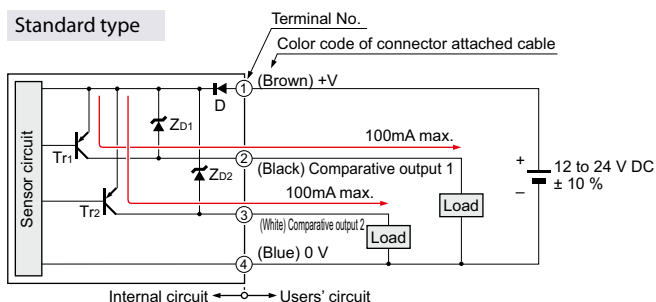

Symbols ... D: Reverse supply polarity protection diode
ZD1, ZD2: Surge absorption zener diode
Tr1, Tr2: PNP output transistor

Multi-function type

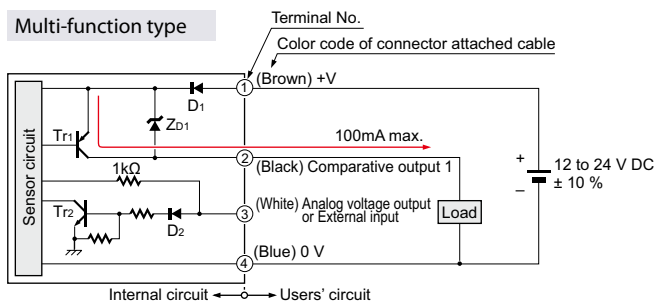

Symbols ... D1, D2: Reverse supply polarity protection diode
ZD1: Surge absorption zener diode
Tr1 : PNP output transistor
Tr2 : NPN input transistor

Terminal arrangement diagram

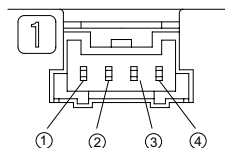

Terminal No.	Designation
①	+V
②	Comparative output 1
③	Standard type: Comparative output 2 Multi-function type: Analog voltage output or External input
④	0 V

FIBER SENSORS

LASER SENSORS

PHOTO-ELECTRIC SENSORS

MICRO PHOTO-ELECTRIC SENSORS

AREA SENSORS

SAFETY COMPONENTS

PRESSURE SENSORS

INDUCTIVE PROXIMITY SENSORS

PARTICULAR USE SENSORS

SENSOR OPTIONS

WIRE-SAVING SYSTEMS

MEASUREMENT SENSORS

STATIC CONTROL DEVICES

LASER MARKERS

Selection Guide

Digital Display

DP-100

DP4

DP-M

Head-separated

DPS / DPH

Other Products

- FIBER SENSORS
- LASER SENSORS
- PHOTO-ELECTRIC SENSORS
- MICRO PHOTO-ELECTRIC SENSORS
- AREA SENSORS
- SAFETY COMPONENTS
- PRESSURE SENSORS**
- INDUCTIVE PROXIMITY SENSORS
- PARTICULAR USE SENSORS
- SENSOR OPTIONS
- WIRE-SAVING SYSTEMS
- MEASUREMENT SENSORS
- STATIC CONTROL DEVICES
- LASER MARKERS
- Selection Guide
- Digital Display
- DP-100**
- DP4**
- DP-M**
- Head-separated
- DP5 / DPH
- Other Products

I/O CIRCUIT AND WIRING DIAGRAMS

DP-11 -E-P-J

NPN output type

I/O circuit diagram

Standard type

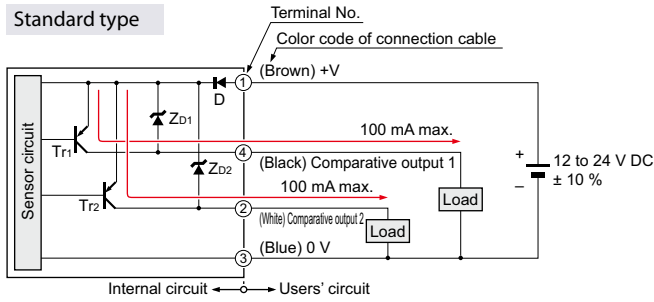

Symbols ... D: Reverse supply polarity protection diode
ZD1, ZD2: Surge absorption zener diode
Tr1, Tr2: PNP output transistor

Multi-function type

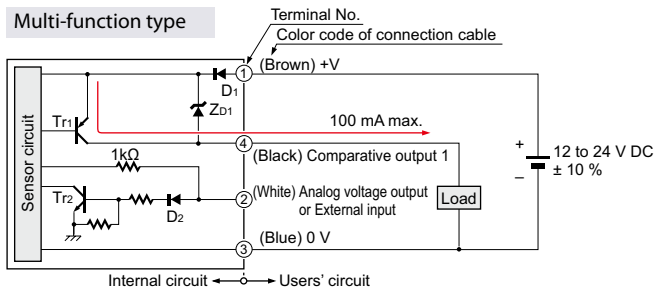

Symbols ... D1, D2: Reverse supply polarity protection diode
ZD1, ZD2: Surge absorption zener diode
Tr1: PNP output transistor
Tr2: NPN input transistor

Terminal arrangement diagram

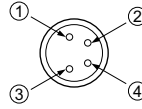

Terminal No.	Designation
①	+V
②	Standard type: Comparative output 2 Multi-function type: Analog voltage output or External input
③	0 V
④	Comparative output 1

PRECAUTIONS FOR PROPER USE



- Never use this product as a sensing device for personnel protection.
- In case of using sensing devices for personnel protection, use products which meet laws and standards, such as OSHA, ANSI or IEC etc., for personnel protection applicable in each region or country.
- The DP-100 series is designed for use with non-corrosive gas. It cannot be used with liquid or corrosive gas.

Connection

- Do not apply stress directly to the connection cable leader or to the connector.

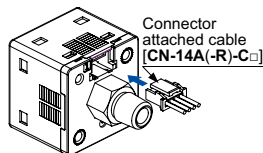

Conditions in use for CE conformity

- The DP-100 series is a CE conformity product complying with EMC Directive. The harmonized standard with regard to immunity that applies to this product is EN 61000-6-2 and the following condition must be met to conform to that standard.

Conditions

- The sensor should be connected less than 10 m 32.808 ft from the power supply.
- The signal line to connect with this sensor should be less than 30 m 98.425 ft.

Mounting

- The MS-DP1-1 sensor mounting bracket is available separately, and it should be used for mounting. When tightening the sensor to the sensor mounting bracket, use a tightening torque of 0.5 N·m or less.

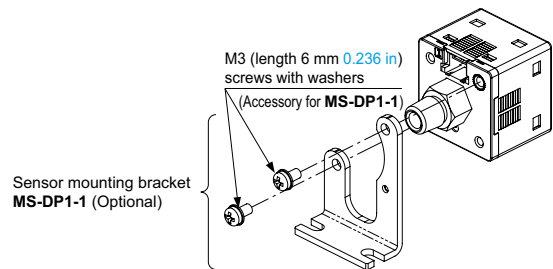

- The MS-DP1-2 panel mounting bracket (optional) and the MS-DP1-3 front protection cover (optional) are also available.

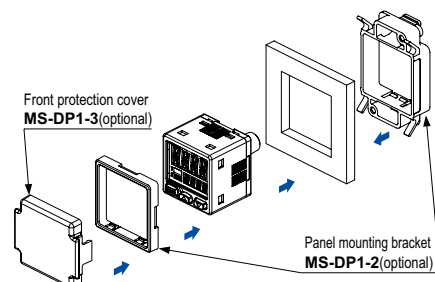

PRECAUTIONS FOR PROPER USE

Refer to p.1004 for general precautions.

Piping

- If connecting a commercially-available coupling to the pressure port, attach a 12 mm 0.472 in spanner (14 mm 0.551 in spanner for DP-100-E type) to the hexagonal section of the pressure port to secure it, and tighten at a torque of 9.8 N·m or less. Hold the short port type DP-10 -M by hand to fix it in place, and mount it using a tightening torque of 1 N·m or less. If it is tightened using excessive torque, it may damage the coupling or the pressure port. In addition, wrap sealing tape around the coupling when connecting it to prevent leaks.

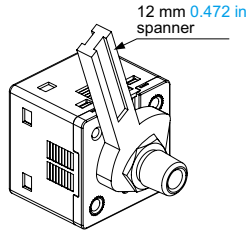

Others

- Use within the rated pressure range.
- Do not apply pressure exceeding the pressure withstandability value. The diaphragm will get damaged and correct operation shall not be maintained.
- Do not use during the initial transient time (0.5 sec. approx.) after the power supply is switched on.
- Avoid dust, dirt, and steam.
- Take care that the sensor does not come in direct contact with water, oil, grease, or organic solvents, such as, thinner, etc.
- Do not insert wires, etc., into the pressure port. The diaphragm will get damaged and correct operation shall not be maintained.
- Do not operate the keys with pointed or sharp objects.

RUN mode

- This is the normal operating mode.

Setting item	Description
Threshold value setting	The threshold values for ON / OFF operation can be changed directly by pressing the increment key (UP) and the decrement key (DOWN).
Zero-adjustment function	This forces the pressure value display to be reset to zero when the pressure port is open on the atmospheric pressure side.
Key lock function	Stops key operations from being accepted.
Peak hold / bottom hold function	Displays the peak value and bottom value for fluctuating pressure. The peak value appears in the main display, and the bottom value appears in the sub display.

MENU SETTING mode

- If the mode selection key is pressed and held for 2 sec. in RUN mode, the mode will switch to MENU SETTING mode.
- If the mode selection key is pressed while a setting is being made, the mode will switch to RUN mode. In this case, the settings that have been changed will be entered.

Setting item	Description
Comparative output 1 output mode setting	Sets the output mode for comparative output 1.
Comparative output 2 output mode setting (standard type only)	Sets the output mode for comparative output 2.
Analog voltage output / external input switching (multi-function type only)	Allows switching between analog voltage output and auto-reference input / remote zero-adjustment input.
NO / NC switching	Sets normally open (NO) or normally closed (NC).
Response time setting	Sets the response time. The response time can be selected from 2.5 ms, 5 ms, 10 ms, 25 ms, 50 ms, 100 ms, 250 ms, 500 ms, 1,000 ms and 5,000 ms.
Display color switching for main display	Allows the color for the main display to be changed. The colors can be set to "red / green" or "green / red" to correspond to ON / OFF output, or it can be fixed at "red" or "green" all the time.
Unit switching (high pressure type only)	Pressure unit can be changed.

PRO mode

- If the mode selection key is pressed and held for 5 sec. in RUN mode, the mode will switch to PRO mode.
- If the mode selection key is pressed while a setting is being made, the mode will switch to RUN mode. In this case, the settings that have been changed will be entered.

Setting item	Description
Sub display switching	Changes the information in the sub display during RUN mode operation to the desired alphanumeric display.
Display refresh rate switching	Changes the display refresh rate for the pressure value displayed in the main display.
Hysteresis fix value switching	Sets the response time for EASY mode and window comparator mode. (8 steps)
Linked display color switching (standard type only)	Allows the display color for the main display to be switched in line with the output operation for comparative output 1 or comparative output 2.
ECO mode setting	Allows power consumption to be reduced by dimming the display or turning it off.
Setting check code	Allows the setting details to be checked via codes.
Setting copy mode	Allows the setting details for the master sensor to be copied to slave sensors.
Reset setting	Resets the settings to the factory settings.

Table of codes

Code	1st digit		2nd digit			3rd digit	4th digit	
	Comparative output 1 output mode	NO / NC switching	Comparative output 2 output mode	NO / NC switching	Analog voltage output / External input		Threshold value display	Display color for main display
0	EASY	NO	OFF	OFF	Multi-function type	P-1, Lo-1	Red when ON	Comparative output 1
1	Hysteresis	NC	EASY	NO	Auto-reference	Hi-1	Green when ON	Comparative output 2
2		NC		Remote zero-adjustment	P-2, Lo-2	Comparative output 1		
3	Window comparator	NO	Hysteresis	NO	—	ADJ.	Always red	Comparative output 1
4		NC		NO	—	Comparative output 2		
5	—	—	Window comparator	NC	—	—	Always green	Comparative output 1
6	—	—	—	—	—	—		Comparative output 2
7	—	—	—	—	—	—	—	—

Code	5th digit	6th digit	7th digit	8th digit
	Response time	Unit switching	Display refresh rate	ECO mode
0	2.5 ms	MPa	250 ms	OFF
1	5 ms	kPa	500 ms	STD
2	10 ms	kgf/cm ²	1,000 ms	FULL
3	25 ms	bar	—	—
4	50 ms	psi	—	—
5	100 ms	mmHg	—	—
6	250 ms	inchHg	—	—
7	500 ms	—	—	—
8	1,000 ms	—	—	—
9	5,000 ms	—	—	—

FIBER SENSORS

LASER SENSORS

PHOTO-ELECTRIC SENSORS

MICRO PHOTO-ELECTRIC SENSORS

AREA SENSORS

SAFETY COMPONENTS

PRESSURE SENSORS

INDUCTIVE PROXIMITY SENSORS

PARTICULAR USE SENSORS

SENSOR OPTIONS

WIRE-SAVING SYSTEMS

MEASUREMENT SENSORS

STATIC CONTROL DEVICES

LASER MARKERS

Selection Guide

Digital Display

DP-100

DP4

DP-M

Head-separated

DPS / DPH

Other Products

DIMENSIONS (Unit: mm in)

- FIBER SENSORS
- LASER SENSORS
- PHOTO-ELECTRIC SENSORS
- MICRO PHOTO-ELECTRIC SENSORS
- AREA SENSORS
- SAFETY COMPONENTS
- PRESSURE SENSORS**
- INDUCTIVE PROXIMITY SENSORS
- PARTICULAR USE SENSORS
- SENSOR OPTIONS
- WIRE-SAVING SYSTEMS
- MEASUREMENT SENSORS
- STATIC CONTROL DEVICES
- LASER MARKERS

- Selection Guide
- Digital Display
- DP-100**
- DP4**
- DP-M**
- Head-separated
- DP5 / DPH
- Other Products

DP-10

Sensor

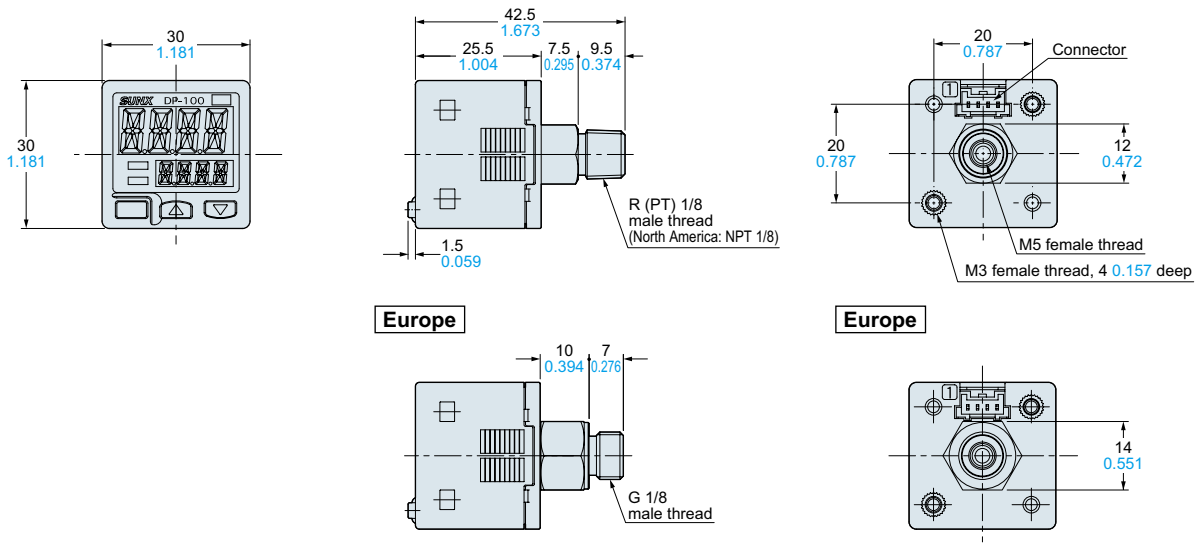

DP-10 -M

Sensor

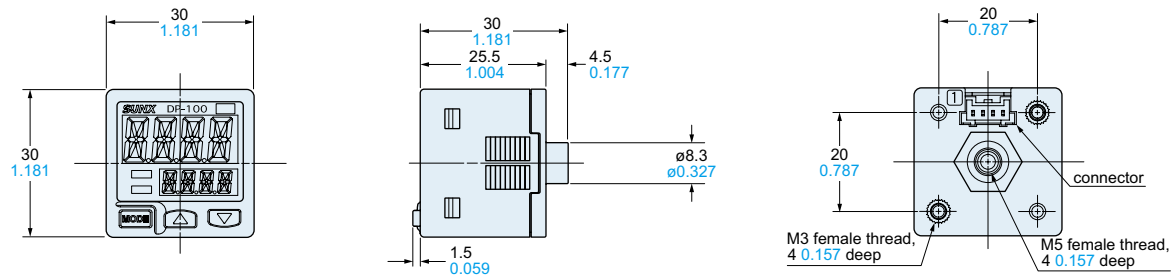

DP-11 -E-P-J

Sensor

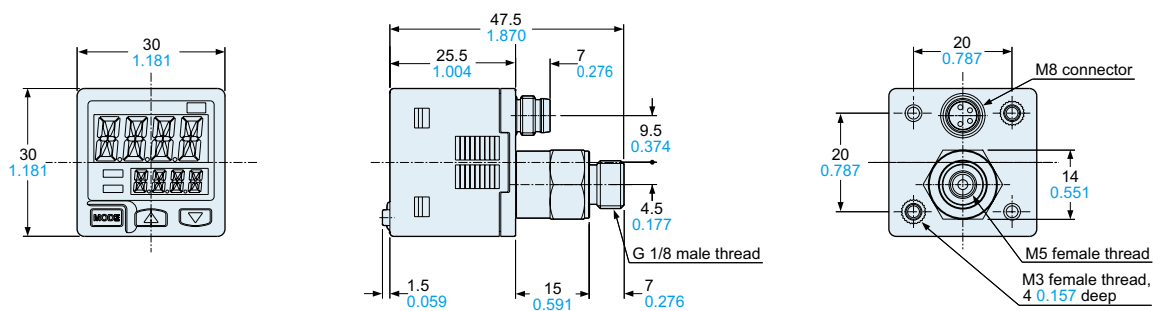

CN-14A-C CN-14A-R-C

Connector attached cable (Optional, CN-14A-C2 is attached to the sensor)

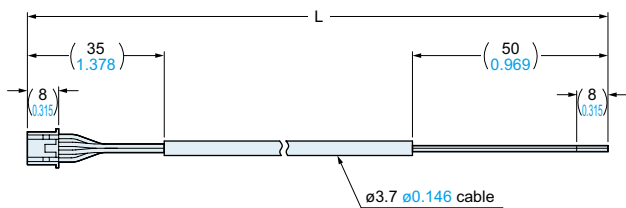

Length L

Model No.	Length L
CN-14A(-R)-C1	1,000 39.370
CN-14A(-R)-C2	2,000 78.740
CN-14A(-R)-C3	3,000 118.110
CN-14A(-R)-C5	5,000 196.850

